



*Open access
to device intelligence*

FDT Technology at Chevron, Today and Tomorrow



The challenging economy isn't stopping San Ramon, Calif.-based Chevron Corp. from "continuing to execute our key strategies," Dave O'Reilly, chairman and CEO, said in March. "In the downstream, we're continuing our program to improve reliability and feedstock flexibility, and we are sharply focused on reducing costs."

This fact isn't lost on the company's engineering services organization, Chevron Energy Technology Company (ETC), where cost reduction doesn't mean putting a halt on wise investments – which explains the company's continuing leadership role in pursuing both the immediate cost avoidance benefits and life-cycle savings inherent in FDT Technology.

Vincent Palughi, Senior Engineer with Chevron ETC, has taken advantage of FDT Technology by leveraging his expertise in FOUNDATION fieldbus and HART communication to facilitate the



Vincent Palughi

company's asset management initiatives. The benefits are twofold: they start in the field with more intelligent devices that are more reliable, allowing rapid start-up and commissioning of facilities, and extend to higher-level automation and management systems allowing many maintenance issues to be resolved from safe areas – minimizing time to repair and trips in the field.



Chevron Smart Initiatives

A company-wide engineering standard has been established that requires all new instrumentation be equipped with "smart" transmitters, where appropriate, to take advantage of the digital data flows for improved process control and instrument maintenance. Additionally, these transmitters must all have DTMs available for implementation.

The greater management role that FDT Technology brings is a deceptively simple and logical extension of the original promise of "open" HART and fieldbus technologies. When engineers and technicians can quickly access a greater set of parameters from any location, they can eliminate trips to the field, speed repair time and reduce maintenance backlog. In short, they can get more work done with fewer resources.

In addition to the time and labor savings, Chevron uses FDT Technology to reduce exposure to safety risks. For example, instead of "suing-up" for a trip to a hazardous area, personnel can troubleshoot automation or safety system components from a safe area like an office or a control room. This provides the obvious protection of safety for the employee entering the hazardous area but also provides a greater degree of safety for the entire operation by eliminating the introduction of additional process hazards as a result of human activity or error.

Offshore Field Commissioning

With rapid plug-and-play compatibility, FDT Technology provided more advanced levels of functionality than standard device descriptions would traditionally provide. In addition to information about the current operating state of the device, historical device performance information is available. Examples include enhanced graphical historic trends of level transducer performance and recording of events such as a valve partial stroke test.

Power Conditioning

Using bus technology, like FOUNDATION fieldbus, in which a single pair of wires is utilized for device power and device communication requires a fieldbus compliant power conditioner. In one Chevron application, multiple power supplies were connected to the H1 FOUNDATION fieldbus segments which fed into a fieldbus compliant I/O junction box. Because the power supplies incorporated open DTMs and the host DCS



Dear reader,

In this editorial, I would like to share with you the milestone that was reached in our certification process. A significant challenge in the implementation of the FDT Group's Technology has been the smooth integration of devices and frames from different suppliers into automation host systems. Because each supplier develops separately their interface, there are potential differences in the implementation of the standard, resulting in interoperability conflicts.

The FDT Group is aware of this obstacle and is fully committed to deliver on its promises of open access to device intelligence. From the onset, we have a strategy to establish a very rigorous and complete certification process providing end users with products that are both conformant to the standard and interoperable.

I am proud to announce that, with the soon to be released frameINSPECTOR and Style Guide 1.1 complementing the already available dtmINSPECTOR 2.0, the FDT Group's strategy is now completed.

The FDT Group offers a comprehensive test process (standard test specifications, test cases and test tools) for the member companies by which the vendors can test the conformance of their product in alignment with the FDT Group requirements. Independent test sites perform the tests and the FDT Group certification office delivers the certificate and posts it on the FDT Web site catalog.

The FDT Group certificate is the official acknowledgement for the fulfilment of the FDT specifications conformance and thus an important asset in the market for manufacturers. Additionally, interoperability testing at the Permanent Interoperability Test Laboratory shall detect eventual integration issues between frames

and devices from different vendors before they are installed in actual projects.

Users can avoid unpleasant surprises at start up and during operation of automation applications, because they can rest assured that our test system most likely has eliminated faults within the frame application and the DTMs.

The FDT Group recommends that end users utilize only certified products, and the recommendation has been heard. Certification is now systematically required as a qualifier for the bidding process and vendors comply by registering their devices. An interesting indicator of this trend is the number of devices registered at the certification office. In just the past fourteen months the number of certified device DTMs grew from 1024 to 1470, a 30% increase! This is also an indicator of the increasing acceptance of the technology in the market.

The complete catalog of certified devices is accessible via the FDT Group internet representation at www.fdtgroup.org. Go and visit it. You will be impressed.

Enjoy reading this newsletter,
Hartmut Wallraf

**Chairman of the Board,
FDT Group**



and asset management systems connected to the junction box incorporated an open FDT frame, Chevron was able to use advanced diagnostic features within the power supply to maximize their investments.

Chevron's Automation Future

Consideration of FDT Technology includes both new and existing facilities because the technology provides both centralized device data access and device data access in the field. Another essential factor is that FDT Technology can be used with a variety of software hosts without the need or expense of a full PAM system implementation.

Going forward, process automation systems at new Chevron facilities will feature a PAM infrastructure that enables remote access to device intelligence using FDT Technology. In existing facilities, the company incorporates the use of FDT Technology by accessing device information in the field.

FDT Technology is critical for project teams being able to meet company cost and schedule directives during the start-up and commissioning of a project that the technology is incorporated in early phases of project execution. To support the technology, Chevron is currently broadening its training to engineers and field personnel to enable them to make decisions and troubleshoot issues to keep up with the demands of facility start-up in the competitive global environment.

Mike Baker, Senior Control Engineer at the Tahiti project, reports that training Chevron personnel along with supplier partners has been "a very useful exercise as the Techs learned how to set-up the instruments, and troubleshoot installation problems by using a laptop to interrogate the instruments."

Palughi adds "I've seen first-hand the reliability-enhancing benefits this FDT Technology offers to the industry," This is important because it helps define interfaces for data flow "horizontally" across facilities as well as "vertically" from field to management systems. ■

FDT Certification

FDT certification ensures the compliance of vendor FDT products against the FDT specification. The FDT products are in two categories namely the DTM and frame application and hence let us examine the details and concept of those certifications from the FDT Group.

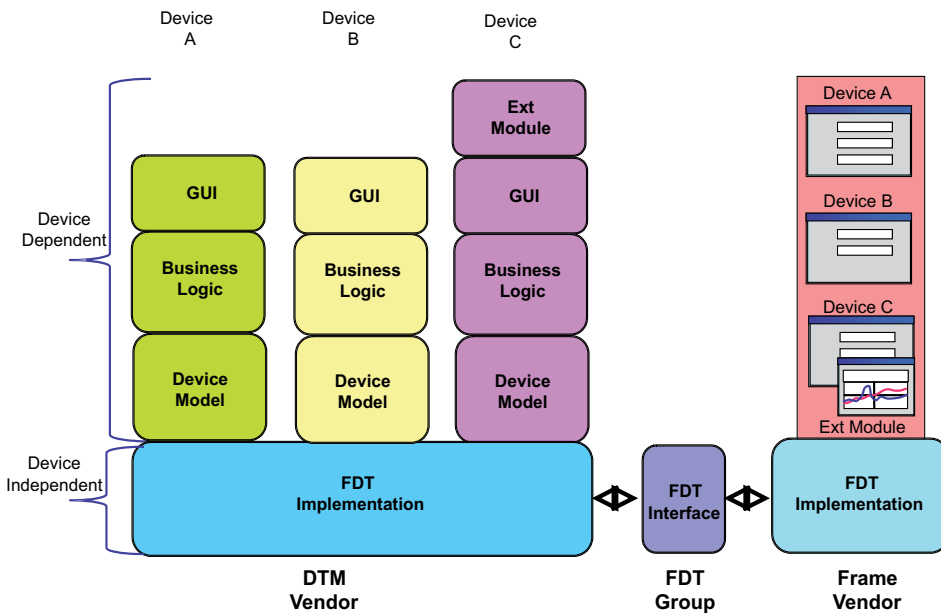

DTM Certification

In order to understand the DTM certification, we have to understand the parts of the DTM and its relationship to the installation package. Conceptually, the DTM software is composed of device dependent and device independent parts as shown in the figure below. Since “FDT Implementation” is a device independent part, the vendors can decide to package

KW-Software FDT-Container

If several devices with different bus protocols should be parameterized in an engineering system without FDT support, the engineering software must support all required protocols. To be able to use the great number of already existing DTMs even in systems not based on FDT, the FDT-Container by KW-Software provides two migration possibilities:

1. The TCI (Tool Calling Interface):

The TCI allows to transfer information for Profibus / Profinet devices from the engineering system to the FDT-Container and DTM. For communicating with the device, the TCI Communication Server or any other communication DTM can be used.



2. Integration of FDT components:

The FDT components provided by KW-Software allow the deep integration into an engineering system or standalone tool on the basis of Automation Framework. Using the Component and Standard UI Framework, any third-party components can be added. Also the integration without Automation Framework components is possible. ■

Further information:

KW-Software GmbH

Mr. Olaf Zarges

Phone: +49 5261 9373-19

Email: ozarges@kw-software.com

Summary

- **FDT Certification**
- **Interoperability testing**
- **Style Guide release planned**
- **CANopen annex**
- **FDT events**
- **FDT Movie**
- **Organizational changes**
- **Meeting with WIB**

the DTM as individual DTMs supporting a particular device type or as group of DTMs for all of their supported device types as a library. From the figure above, this means that the vendor can package the device type of the supported DTM in individual installation packages or all in one installation package as DTM_LIBRARY setup that supports all the device types.

The FDT Group checks the “FDT Implementation” of a DTM library for its conformity against the FDT specification. The conformity is tested by a tool called dtmINSPECTOR. It is able to detect whether the “FDT Implementation” of the vendor is able to support more than one device type. If this is the case, then any one of the supported device types is used for the certification testing. The “FDT Implementation” is also tested for data communication with the device. However the validity of the data is not in the scope of FDT testing.

The FDT certificate will provide the details of the tested device type and supported device types and confirms the behavior of the “FDT Implementation” of the DTM





library with respect to the FDT specification. The vendor also confirms to the certification office that the device independent "FDT Implementation" remains the same for all the supported device types packaged on the library.

More and more certificates are issued every day, covering a large part of the instrumentation available on the market.

Frame Certification

The FDT Group checks the "FDT Implementation" of a frame application for its conformity against the FDT specification by a tool called frameINSPECTOR. The frameINSPECTOR is currently available in beta version. The final certification version is scheduled to be released by June 2009.



■ Total number of Certified DTMs (Cumulative)
■ Total number of Supported Device Types (Cumulative)

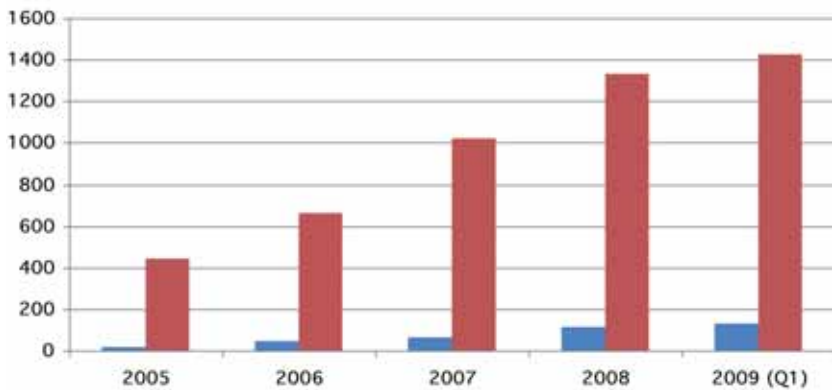

M&M Software fdtCONTAINER application with hartCOMMDTM and hartDEVICEDTM

M&M Software included a HART device DTM and a HART communication DTM into the proven FDT frame application fdtCONTAINER application. Both DTMs are designed in a universal way, meaning they are working with nearly every HART field device and HART modem. The functionality of the hartDEVICEDTM covers the reading of the HART universal

commands and is therefore perfect for accessing the basic parameters of a HART device. The hartCOMMDTM is able to handle both, HART modems connected by USB or a serial line and any HART device DTM could be connected to it. Both DTMs are fully included in the setup of the fdtCONTAINER application. Therewith, the user gets one common solution for setting up HART devices in a very easy and fast way. Thus, the fdtCONTAINER application with its integrated HART DTMs is perfect for testing purposes and small installations.

For more information please contact Christian Gnädig: cgg@mm-software.com +49 7724 9415 60



Upcoming events

- **Hanover Fair, DE**
(20.04.2009 - 24.04.2009)
Hall 11 Booth A12
- **FDT Press Conference**
Hanover Fair, DE
(22.04.2009 - 10.30 am)
Convention Centre 105/106
- **FDT and ISA Technical Seminar Vallejo, CA**
(05.05.2009)
- **Achema 2009, Frankfurt, DE**
(11.05.2009-15.05.2009)
Hall 10.2 Booth D15-E18

FDT multivendor test stand at Dietz Automation

On User Forums, interoperability has been a concern and priority for the end users of FDT products. Hence, the FDT Group organized some Interoperability Projects for the years 2005-2007. In these projects, device vendors and system vendors participated in a workshop environment to improve the interoperability of their FDT products with other participating vendors. During the course of Interoperability Projects a multivendor test system was built up and continuously extended and updated. This multivendor test system that was used previously in workshops on need basis now has been established permanently by the FDT Group at Dietz Automaton in Neukirchen, Germany. This multivendor test stand is accessible to all FDT members and will be maintained by the FDT Group and operated by Dietz Automation. The FDT Group has defined interoperability test cases which can be





used by the participating vendors to test their DTMs or Frames against various other FDT products available on the test stand.

The current multivendor system consists of 10 FDT frame applications (systems or engineering tools) from 6 vendors and a large number of components and devices with their DTMs. It uses the most familiar digital protocols PROFIBUS, HART, and FOUNDATION Fieldbus. Also Dietz Automation made efforts to access the

multivendor test stand via remote testing for the FDT developers all around the world.

The FDT Group members are encouraged now to use the opportunity to test their products for interoperability in a large and diverse multivendor FDT environment to improve the interoperability of their products with the various available products on the test stand. ■



New DTM Style Guide 1.1

prior to publication



Joachim Tschampel

After a 3 year pause the “DTM Style Guide” project group headed by Joachim Tschampel from ICS restarted a new round of discussion in 2008. The kickoff meeting took place at Shell Global Solutions, Amsterdam in January 2008.

This time the goal was not only to involve device manufacturers for process automation industries in the discussion but to also make end user member companies of the FDT Group and device manufacturers for factory automation systems participate.

Furthermore, the experience of developers using DTM Style Guide 1.0 was taken into account, recent NAMUR NE107 icons had to be included and a better usability of DTMs was the focus of the project group’s work.

Finally, 10 member companies contributed their work force to the project group, including; ABB, Foxboro Eckardt, ICS, Omron, Pepperl+Fuchs, Schneider Electric, Shell Global Solutions, Turck, VEGA and Wago.

New and often required elements were added to the Style Guide like a “wizard user interface”, additional buttons in the action area and a definition of user role related default applications.



ifak system

New Version 3.1 of isEDDview DTM released

The isEDDview DTM supports HART and PROFIBUS devices based on the interpretation of EDDL.

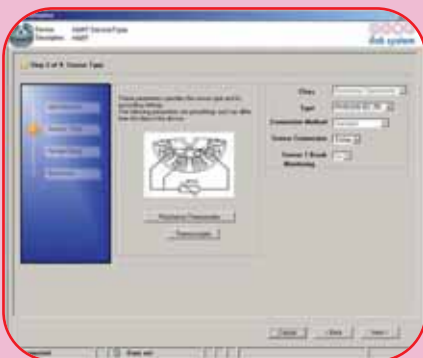

With version 3.1 the isEDDview DTM has been updated to provide better support especially for HART devices.

While HART specific improvements focus on optimization of communication performance and a better handling of communication problems, other improvements were included in order to enhance the handling of PROFIBUS devices. Examples for such enhancements are the upgraded handling of EDD-based wizards (MenuDisplay), enhancements for adaptive GUIs and for method execution. The graphical display elements have been updated to improve

direct user interaction and provide better feedback in case of communication problems.

Customers appreciate the good overall performance and stability of the isEDDview DTM and have found the DTM not only comparable to other existing device management tools, but also acknowledge the outstanding support of advanced EDD language features. ■





A synchronized application was defined because this seems to be mainly used in factory automation applications. Some icons were slightly redesigned to give better feedback to the user. And last but not least, a dictionary of standard terms and phrases in five Western European languages, Russian and Japanese to be displayed by DTMs was added.

After 8 meetings the group agreed to present a draft to the WG A&S for a review. The review comments of the WG A&S were carefully discussed and agreed on in February, 2009. We are now waiting for the FDT Group member review in order to publish the new DTM Style Guide in the near future.

As it is planned to make the certification of DTMs with respect to style guide conformance mandatory - end user companies and organizations like NAMUR have demanded this for a long time - a checklist was prepared for certification tests executed by the accredited test sites. A short manual describes how to use the checklist that has to be adapted to the properties of individual DTMs. In order to receive a certificate, 100% of the valid test cases must be fulfilled in order to guide the user through a high number of DTMs in a plant developed by many different manufacturers in a secure and appropriate manner. ■

ARC Process Management Academy Düsseldorf



From March 2 to 4, the FDT Group was present at the ARC Process Management Academy in Düsseldorf, Germany. The event was attended by about 200 visitors mostly from the surrounding German process industry. The FDT Group sponsored the event and advertised it on its website.

We had a small booth where we distributed marketing material and answered questions from visitors.

During the event, suppliers and end users gave presentations, mostly in English,

which shows the growing international character of this event. The subjects were grouped according to 4 themes: Operational Excellence, Safety and Security, Asset Optimization and PLM and Engineering. Also some excellent key notes speeches were scheduled.

On March 4, our FDT Group Chairman, Hartmut Wallraf (IPS invensys) presented "Commissioning and Maintenance of Field Devices with FDT-DTM in a Petrochemical Plant" as part of the Asset Optimization Sessions.

Overall, this event gave the FDT Group a good visibility in the process automation market in Germany. ■



Hartmut Wallraf

Hilscher

Smart FDT/DTM Development Services

Company Hilscher crowned with success as a supplier of cutting edge industrial communication technology delivers unmatched number of in-house developed FDT/DTMs for various



protocols completed with FDT Frame Application SYCON.net.

With SYCON.net, available as a stand-alone application or an embedded component for various engineering systems from different vendors, you get an FDT based complete solution for all fieldbus systems and real-time Ethernet based protocols from one source. The complete work

- is developed by engineers with fieldbus know-how
- supports PROFIBUS, CANopen, DeviceNet
- supports PROFINET IO, EtherNet/IP, EtherCAT, SERCOS III
- includes generic DTM solutions

- allows configurable Gateway-DTMs with wide range of protocol combinations
- provides Process Data Interface for the SPS linking

Beyond this, Hilscher is going to provide Smart FDT/DTM Development Services for third party field devices.

Put us to the test and talk with us about our unique solutions for your devices – customized smart DTMs: communication, (generic) Device and Gateway DTMs ■



FDT goes for an OSCAR!

Are you looking for an easy to understand introduction to FDT and its benefits? Have you always thought it would be nice to have something else to explain FDT than just a normal PowerPoint presentation?

Just follow this link to see our brand new FDT movie! www.fdtgroup.org

Find out more about how FDT can be implemented in any plant; learn about its benefits throughout the whole life cycle and its vendor as well as communication protocol independence. You will also see an interesting interview with a customer about his experiences with FDT.

An international project team out of the FDT Group's Marketing Committees put together the ideas and storyboard for this movie. It is available in a short and long version in three languages English, German and Japanese.

Please share it with colleagues, customers or also with your wife (as this is now finally an easy way to show her what this cryptic three letter abbreviation "FDT" is all about...)! ■



Endress+Hauser releases new FieldCare Version 2.06.00, including new iDTM-HART and new DTM Library

Endress+Hauser announces the release of Version 2.06.00 of the Asset Management Package FieldCare.

The segmentation of FieldCare has been renewed, the current "Lite" version is now included in the "Device Setup" Version, which makes it the most powerful free of charge FDT Frame Application on the market.

Furthermore, a Mobile Laptop Manager is available for documentation manage-



FieldCare

ment, which enables a user to exchange data sets between different FieldCare installations. Also the connectivity into the life-cycle management platform W@M has been enhanced. Additionally, FieldCare now has a launching interface to be launched directly from a third party tool.

iDTM-HART Version 1.01.00 is also included, containing the latest HCF DD library and allowing a user to add DDs themselves, if any are missing. An iDTM for FOUNDATION Fieldbus will follow in FieldCare 2.07.00.

The package also includes the latest version of the Endress+Hauser DTM Library, Version 2.22.00. ■

For further information please contact klaus.korsten@solutions.endress.com

Endress+Hauser 
People for Process Automation

FDT annex for CANopen in member review



The FDT annex for the CANopen network protocol is finished. The annex describes how to communicate with CANopen devices using FDT Technology. Included are descriptions of XML schemas which are required to implement a DTM for devices connected to the CANopen protocol. The annex is currently in member review, lasting four weeks. All FDT members are called to send their comments to Joerg Knierriem (joerg.knierriem@de.schneider-electric.com) who is the head of the CANOpen working group within the FDT Group. After the review phase which will expire on April 23 2009, the release of the annex is expected for June 20 2009.

In the CiA - an international group of users and manufacturers that develops and supports CANopen based products -





approximately 500 companies are organized. Therefore, the FDT annex for CANopen is a step further, bringing the FDT Technology into the various branches of factory automation. ■

FDT exhibits and holds press conference at 13th Annual ARC Forum in Orlando

The FDT Group participated in the 13th Annual ARC Forum, "Winning Strategies and Best Practices for Sustainable Manufacturing" on February 2-5 in Orlando, Florida USA. With over 450 in attendance, the event was well attended by industry professionals eager to learn more about technologies that provide sustainable bottom line business benefits.

The FDT Group showcased a technology demonstration in which attendees learned the value of a DTM for commissioning and maintenance activities and explored the relationship between DTMs and the various frame applications that are available on the market today both as stand alone applications and part of major automation vendors automation system.

Shannon Foos, Director of North America Marketing, held a press conference on February 2nd highlighting the latest organizational and technology developments. The headlines included a 20% membership increase with new FDT Group

members such as North American based BusCorp and Dresser Masoneilan bringing total FDT Group membership to 70 end user companies, automation suppliers, service providers, and universities.

Progress on FDT Technology standardization efforts was also communicated. The international standardization effort, IEC 62453, is expected to culminate in final release July 2009 while ISA103 standardization activities continue to focus on adoption of the international standard within that organization.



A 2009 event update indicated several activities are planned for North America including seminars in four locations - Calgary and Edmonton, Alberta; Baton Rouge, LA; and Vallejo, CA. Additionally, lunch and learn sessions have been scheduled with end users, along with tradeshow events such as ISA.

Looking forward, priorities for the year include participation in activities leading to advancements within FDI, movement to increase FDT Technology adoption in factory automation, efforts to fulfill NAMUR 105 requirements for greater adoption in a variety of geographic regions and applications, and updating the certification process to include frame



Rockwell Automation announces the PlantPax Process Automation System

Rockwell Automation is delivering a unified automation control platform that delivers unmatched capabilities for process and other plant-wide applications. This has culminated with the PlantPax Process Automation System. After seeing the results of this year's CONTROL Magazine Readers' Choice

Awards, it's evident that manufacturing professionals recognize the performance and reduced costs this unified platform provides. When including instrumentation partner Endress+Hauser, the Rockwell Automation system scored a total of 34 first place Readers' Choice finishes. Even more importantly, most of the company's wins came in the vertical markets, where process platforms were rated on their system capabilities rather than on particular components. Specifically, preference was shown in these process industries: beverage, food, electric/power generation, pharma/life sciences, metals/minerals/mining, plas-

tics/rubber, pulp & paper, water/waste water. ■

Overall, Rockwell Automation received 60 1st-4th place finishes, providing Rockwell Automation a claim to the title of the readers' overall favorite process and plantwide control provider based upon the PlantPax (TM) Process Automation System capabilities. You can view the full results at http://www.controlglobal.com/digital_edition/2009/0901/flash.html#/1/





certification to enhance the user experience. Summing up the busy but exciting year ahead for the FDT Group, Foos closed by saying, "The FDT Group has made considerable progress. Being able to see the completion of the International Standardization activity allows the organization to focus on additional activities that will further the FDT Group's mission of open access for device intelligence."

For more information about the annual ARC Forum or the FDT press conference, please visit www.fdtgroup.org/na.

FDT Group Organizational Changes

Three Board of Directors members have changed position in their company and will be leaving the function in FDT. Mr. Markku Simula is now vice president, Neles Products within Metso Automation. He will be replaced by Mr. Mikka Nissinen, Director Smart Products Neles Products. Mr. Cyril Perducat, from Schneider Electric has also changed assignment and his replacement will be Mr. Ronald Schoop, president of Schneider Electric Automation GmbH, Automation Business Unit. Finally, Mr. Satoru Kurosu has accepted the position of Senior Vice President, Head of Global Business Headquarters, Yokogawa Electric International, and will be replaced by Mr. Kimikazu Takahashi, Chief Technical Officer (CTO), Industrial Automation Business Headquarters, Yokogawa Electric Corporation.

Also, in the FDT Group Executive Committee, we welcome two new representatives: Mr. Ryan Kromhout, who replaces Mr. Frank Rohn as representative of the PACTware Consortium, and Mr. Henk van der Bent who will occupy the Executive Committee position for Yokogawa, in replacement of Mr. Yoji Saito.

Finally, Mr. Achim Laubenstein of ABB Automation stepped down from his position as FDT Vice President Technology. As of today, this position is fulfilled by Mr. Tetsuo Takeuchi of Yokogawa.

On behalf of the FDT Group we thank the departing people for their support and contribution to the FDT Group and welcome the new members, looking forward to productive participation in the Group's activity.

ICS

First Series of DTM Master Based DTMs Certified

The DTM Master Concept provides a very efficient and reliable way to build complex DTMs. Most DTM-elements like the user interface, parameter model and communication protocols can be constructed. Private functions can be implemented such that a basic DTM is extended with sophisticated functionality turning a DTM into a really useful tool for the end user.

The first 5 DTM Master based DTMs have not only successfully passed the certification procedure in one run but are intensively tested against all important FDT containers.

DTM Master-based DTMs are future-oriented because they are style guide compliant and a 100% .NET implementation based on state-of-the-art software architecture. The DTM Master Concept was approved by developers of device manufacturers as a highly usable solution.

For more information please contact:
ICS GmbH

Pforzheimerstr. 202C
76275 Ettlingen, Germany
Phone: +49 7243 7127-0
Fax: +49 7243 7127-29
sales@icsgmbh.de
www.icsgmbh.de

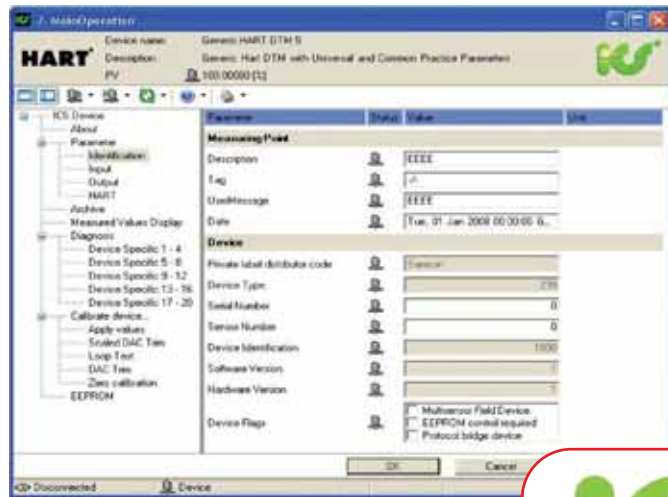

Lunch and learns on FDT Technology

North American end users advance ability to increase plant performance with lunch and learns on FDT Technology

FDT Technology is peaking interest among automation professionals as news of FDT Technology spreads through the region. In order to continue the communication flow, the FDT North American Marketing committee has developed a lunch and learn program to educate the end user community on the importance of and what can be achieved with the technology. In an hour and a half, attendees will

be presented with an overview of just how this technology fits into new or existing plants infrastructures by providing bottom line benefits such as asset management integration, diagnostics and plant life cycle solution. A technology demonstration will follow illustrating the value of FDT Technology for commissioning and maintenance activities. The demonstration will also explore the relationship between DTMs and the various frame applications that are available on the market today, both as standalone applications and part of major automation vendor systems. Lunch and learns are planned with Shell Chemical LP - Geismar Plant in April and Genentech in May, with more to be scheduled in the latter half of the year.



Dietz Automation establishes new branch office in Hanover

„Convincing business concepts, promising products and innovative services to be realized in the region of Hanover“ was the requirement of the foundation and establishment competition „Plug & Work“ of the economic development company Hannoverimpuls.

Dietz Automation is one of the awardees and is thus promoted by Hannoverimpuls.

At first of January 2009 Dietz Automation established a new branch office under the direction of Mr. Ingo Mauritz in the TCH. Thus the services of Dietz Automation are moving closer to the customers in the north of Germany.



The office provides services around automation systems as planning, engineering and trouble shooting in fieldbus systems. On request special trainings for companies concerning automation subjects are offered.

Furthermore the new office is part of the manufacturer independent test site for FDT Technology. There all kinds of manufacturer and product specific tests and solutions are provided. ■

Contact: Ingo Mauritz,
Tel: +49 (0)511 9357 220
ingo.mauritz@dietz-automation.de

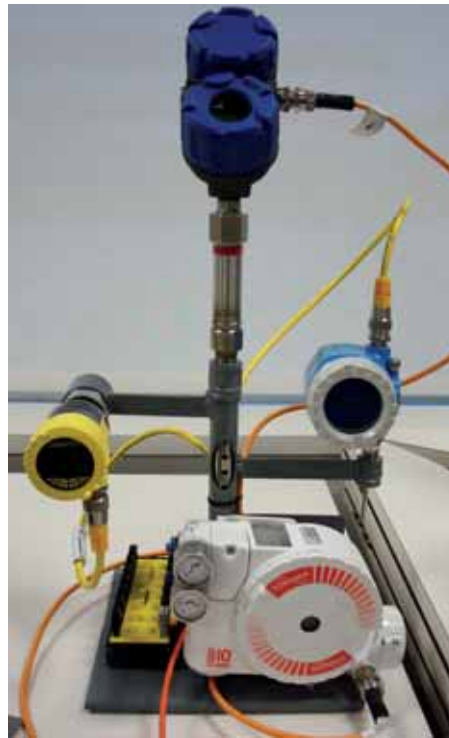

If your company is interested in learning more about FDT Technology and would like to schedule a lunch and learn at your facility, please contact na.marketing@fdt-group.org. ■

For more information on FDT and North America activities, please visit www.fdtgroup.org/na.

Review Meeting between WIB and FDT Group

On March 17th the FDT Group held its yearly review meeting with WIB.

WIB is an International Instrument Users' Association based in the Netherlands. It is a non-profit organisation providing advisory services to process plant owners and engineering consultants around the world for the best selection of process instrumentation and systems for process automation. WIB members are multinational companies but also engineering contractors and medium-sized process and manufacturing companies. Some of their members, like Shell, are among the largest users and strongest supporters of FDT Technology.

The FDT Group holds yearly review meetings with WIB where we update them on the progress that we achieved on their concerns and inform them on the new developments of the technology. These meetings usually give place to lively discussions in a friendly atmosphere. We learn directly from the end users their daily experience with FDT Technology and its practical utilization in everyday operations. We try also to explain some aspects of the technology that are difficult to understand directly for non specialists. ■



Prosoft Technology

PROFIBUS modules with FDT/DTM and CIP backplane messaging

ProSoft Technology's new PROFIBUS DP Master and Slave modules for the Rockwell Automation CompactLogix platform are PROFIBUS certified, offer DPV0/V1 support, and are configurable using the PROSOFT.fdt Configuration Software. The Master module (PS69-DPM) provides 204 words input / 240 words output and supports both I/O

control and CIP messaging for parameterization. CIP messaging reduces the amount of information that is continually updated in the processor by separating the non-critical (acyclic) data from the critical (cyclic) data. This allows for non-critical data to be sent upon request only, which can significantly speed up performance. Master DTM included for FDT Asset Management, with support for PACTware, FieldCare, and other FDT-compliant containers. The slave module (PS69-DPS) supports CIP messaging and can be configured via ladder logic or PROSOFT.fdt software. ■



<http://www.prosoft-technology.com/profibus/>





This year's meeting was no exception. It was held at the Heineken head office in Zoeterwoude, NL. The following companies were represented; DuPont, Akzo Nobel, Exxon Mobil, Heineken, DSM, Dow, BASF/Wintershall as well as WIB staff and consultants.

A solid FDT representation was able to position effectively the progress and developments in technology as well as clarifying some of its special features.

The FDT Group looks forward to continuing these reviews that are most useful to the progress and acceptance of the FDT Technology. ■



ISA dinner in Al Khobar

On January 26th, the FDT Middle East Marketing Committee sponsored the ISA dinner at the Dhahran International Hotel – Al Khobar, Saudi Arabia.

This event was attended by about 50 members of the Saudi Arabian ISA

Section. Most of them are Saudi Aramco employees.

Hussein Zein, Technical Sales Consultant for Invensys Saudi Arabia, made a presentation about FDT entitled "FDT/DTM: Open Access to Device intelligence".

Zein emphasized the unique approach of each vendor in today's plants to asset performance management functions inside their device, hence the variety of fieldbus protocols and configuration tools. Also, users need the best of both worlds - all the basics for asset management from the host system vendor, plus the specialized in-depth device analysis tools from the device vendor.

With this background, he explained the key feature of FDT Technology - its independence from the communication protocol and the software environment of either the device or the host system. DTMs allow delivering advanced device-specific applications to the plant's maintenance staff.

The speaker was introduced by Nabil Nader, the Chairman of the FDTMEMC and employee of Turck. He also gave a short introduction on the FDT Group.

Hanover Fair and ACHEMA FDT will be present

The FDT Group will participate at the Hanover Fair on April 20-24, 2009 in



Hanover, Germany. The FDT Group booth will be located in the same location as last year: Hall 11, booth A12.

We will also participate in ACHEMA 2009 on May 11-15, 2009 in Frankfurt, Germany. This fair is organized every 3 years and focuses on the chemical industry. Our booth will be located in Hall 10.2, booth D15-E18.

The booths will be sponsored by Dresser Masoneilan, Endress+Hauser, Hilscher, ifak system, KW-Software, Metso, PACTware, Pepperl+Fuchs, Phoenix Contact, Samson, VEGA, and Yokogawa.

Our booth sponsors will be demonstrating interoperability between their different products (frames, devices, gateways, Remote IO's, etc.) and the nested communication of FDT Technology, allowing the customer to navigate through the structure of his plant from his PC in the control room. ■

Honeywell

FDM Provides Profibus Support through FDT/DTM Technology

Honeywell Field Device Manager (FDM) simplifies configuration and maintenance tasks and enables remote management of smart instruments. With



command and control throughout the plant, FDM helps improve smart device effectiveness.

In 2007, FDM Release 301 introduced FDT/DTM support for HART devices connected to Experion PKS and non-Experion I/O. Maintenance users can easily choose a DD/EDDL or DTM view of each device. A DTM can provide a rich graphical interface and simplify complex operations. FDM provides the full benefit of advanced vendor created software in the familiar FDM environment.

Honeywell recently expanded this

FDT/DTM offering by adding support for Profibus devices in FDM Release 310 via Device, Communication and Gateway DTMs. Features include a Profibus topology view, Profibus PA and DP device support, and HART-over-Profibus Remote I/O support. Now, users can manage even more smart devices through one comprehensive and powerful tool. ■

*John Yingst, Product Manager
Honeywell Process Solutions, Phoenix, AZ*

Honeywell

Win an iPod at the FDT Booth!

We invite you all to visit us at Hanover Fair or ACHEMA and participate in our “How well do you know FDT?” quiz. Out of all correctly completed participation forms, we will pick one winning questionnaire for each fair and the winner will receive from us a brand new iPod!



FDT Group member companies



To subscribe and unsubscribe, please follow this link:

<http://www.fdtgroup.org/en/newsletter>

Please feel free to forward this newsletter.

For further information please visit www.fdtgroup.org or contact the FDT Group Business Office:

FDT Group AISBL Culliganlaan 1B - 1831 Diegem - Belgium - Phone: +32 (0)2 403 13 33 - Fax: +32 (0)2 403 12 12 - Email: businessoffice@fdtgroup.org